



Quality you trust. Experience you know.

XeOTB615 / XeOTH615 REDLINE Spiral Mixers with attached lifter



Features:

- Stainless steel bowl, spiral dough hook, and shaft
- Separate bowl and agitator motors
- Has two speeds and reverse function
- Control board has separate timers for 1st and 2nd speed
- Mixer is equipped with built in lifter for lifting and dumping mixed products
- Lifter can tilt machine left or right (must specify when ordering)
- Difference between the the H and B models is the height of the lifter
- Safety switches protect operator from injury when bowl lid is open
- Powerful belt drive provides low vibration, low noise, and economical maintenance for years of reliable service

Models:

- XeOTB615:
615lb(280Kg) dough capacity Spiral Mixer.
- XeOTH615:
615lb(280Kg) dough capacity Spiral Mixer.



Speeds:

Dough Hook:	Bowl:
1st speed: 95rpm	1st speed: 15rpm
2nd speed: 190rpm	

Warranty:

- One year, on-site parts and labor



Warranty Details

The XeOTB mixers carry a one-year, on-site parts and labor warranty against any flaws in materials and workmanship. This period begins on the date of the purchase and, provided the unit is used in accordance with our instructions, is in full effect for one year from that date. Any work performed under this warranty must be performed between the hours of 8am and 5pm Monday through Friday. Xebeco will not pay for overtime charges for work performed other than during normal business hours. Damage incurred in transit or from installation error, accident, alteration or misuse is not covered. Xebeco shall not be liable for any consequential compensatory, incidental, or special damages. Contact the Xebeco service department for any warranty claims.

Quality you trust. Experience you know.

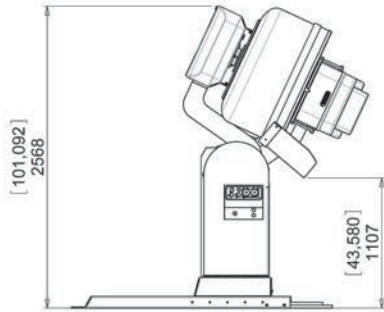

XeOTB615

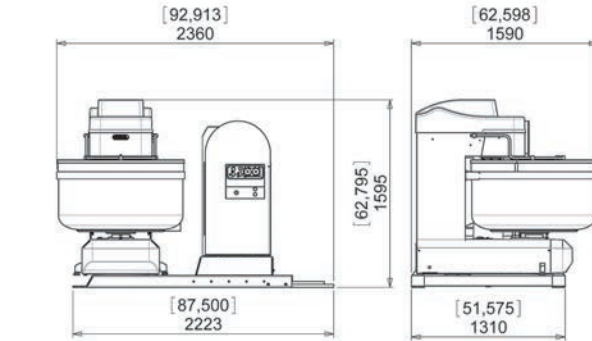

XeOTH615

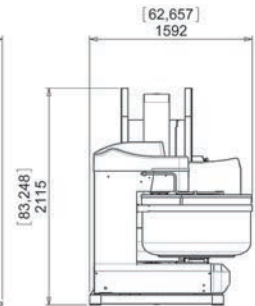
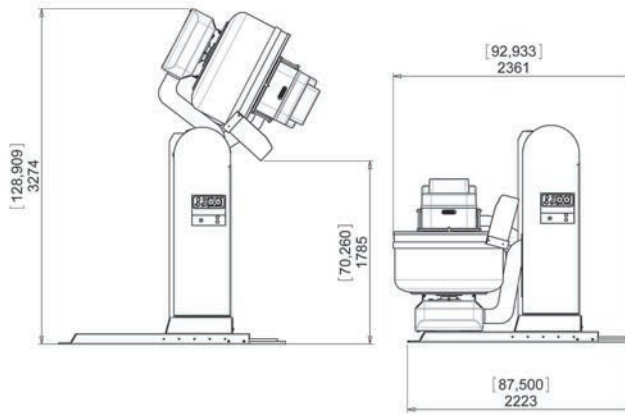

Spiral:
XeOTB615: 14.75HP
XeOTH615: 14.75HP

Lifter:
XeOTB615: 3HP
XeOTH615: 3HP

Bowl:
XeOTB615: 1HP, 4.48A, .75KW
XeOTH615: 1HP, 4.48A, .75KW

Electrical: 380V/60Hz/3P (Contact factory for alternate voltages)

Controls: Control panel with digital timers. Separate timers for high and low speed. Security key for manual use. Bowl reverse direction switch.

Transmission: Heavy duty low noise, low vibration belt drive

Bowl Guard: Swings open for full access to bowl. Guard must be closed for mixer operation.

Shipping Information:

	XeOTB615	XeOTH615
Freight Class:	85	85
Net Weight:	44091b (2000kg)	37481b (1700kg)

Cartons are affixed to a pallet. The pallets are heat-treated and NELMA approved for international shipping. The weight and dimensions of the pallet are included in the weight and dimensions above.

